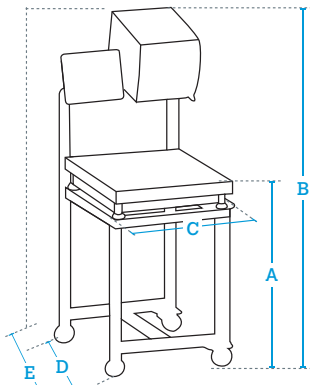



Image of the ML structure with
Dibal LP5000 manual touch screen
labelling equipment and platform.
(Weighing and labelling
equipment not included)

DIMENSIONS



DATA IN mm

A	905
B	1,470
C	600
D	755
E	1,005

Weight with packaging: 60 - 200 kg.

*Dimensions with LP5000 solution + platform 600x600 mm, not included.

Models

ML FRAME WITH WHEELS

- Valid for LP5000.

Ref: **7500000Z001187**

ML FRAME WITH WHEELS WITH DRAWER FOR PRINTER AND COVER FOR CONSOLE

- Valid for LP5000.

Ref: **7500000Z001189**

ML FRAME WITH WHEELS WITH SUPPORT FOR VT-1200 AND ANOTHER PRINTER*

- Valid for VT-1200.

Ref: **7500000Z001188**

ML FRAME WITH WHEELS WITH SUPPORT FOR VT-1200 AND DRAWER FOR ANOTHER PRINTER*

- Valid for VT-1200.

Ref: **7500000Z001190**

*Compatible printers:
> TOSHIBA models: BA410T BA410T-GS12-QM-S or EX4T1 B-EX4T1-GS12.
> BIXOLON model: IIE48 LABELS 4" 8 dots [XT5-40D9S].

ML FRAME WITH WHEELS

- Valid for DMI.

Ref: **7500000Z001187 + 497536A**



*Example of customized ML solution with VT-1200, platform and external label printer.